

Grumble Skuzz

DESCRIPTION

Essentially a modified Kay F1 Fuzztone, which itself was just a simplified Univox Super Fuzz, the GRUMBLE SKUZZ follows the lead of Jack White's Third Man Records Bumble Buzz offering up some unapologetic, no frills, fuzz. Besides its unruly wall of tone, the GRUMBLE SKUZZ has some octave up characteristics when playing higher up the fretboard on the neck pickup, and sounds great when pushed with other boost or dirt boxes.

SCHEMATIC

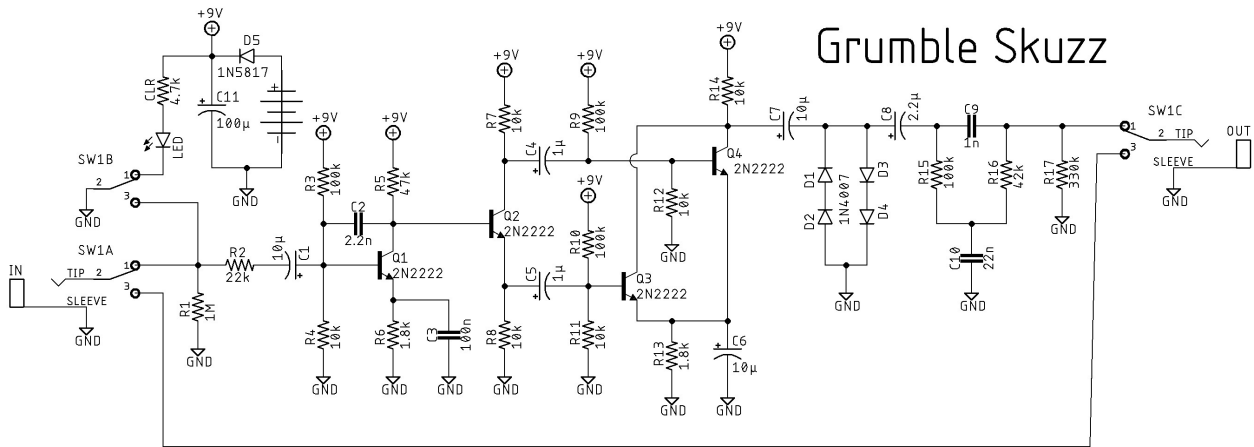

LAYOUT

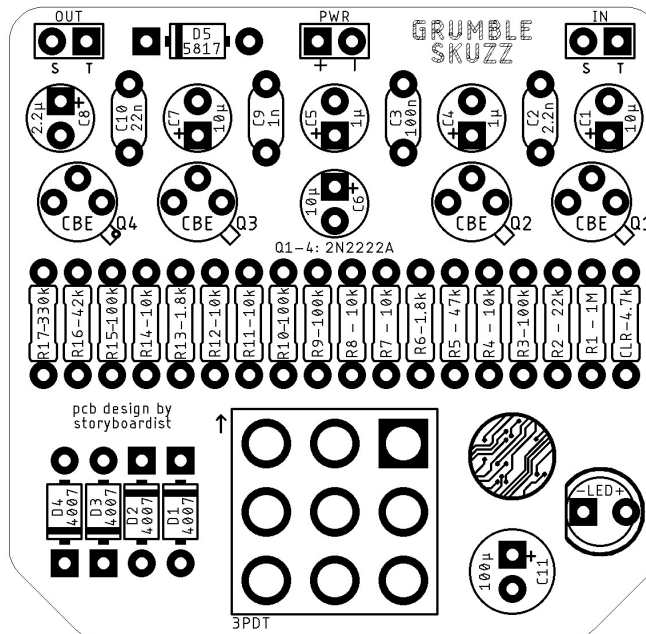

BOM

Resistors

R1	1M
R2	22k
R3	100k
R4	10k
R5	47k
R6	1.8k
R7	10k
R8	10k
R9	100k
R10	100k
R11	10k
R12	10k
R13	1.8k
R14	10k
R15	100k
R16	42k
R17	330k
CLR	4.7k

Capacitors

C1	10 μ
C2	2.2n
C3	100n
C4	1 μ
C5	1 μ

C6	10 μ
C7	10 μ
C8	2.2 μ
C9	1n
C10	22n
C11	100 μ

Semiconductors

D1	1N4007
D2	1N4007
D3	1N4007
D4	1N4007
D5	1N5817
LED	3 or 5mm
Q1	2N2222A
Q2	2N2222A
Q3	2N2222A
Q4	2N2222A

Electromechanical

Footswitch	3PDT
------------	------

Notes

On the silkscreen, the +/- label on the LED is backwards. The square pad is the cathode (-), and the round pad is the anode (+).

SHOPPING LIST

Value	Type (suggested)	Quantity
1.8k	¼ watt metal or carbon film	2
4.7k	¼ watt metal or carbon film	1
10k	¼ watt metal or carbon film	6
22k	¼ watt metal or carbon film	1
42k	¼ watt metal or carbon film	1
47k	¼ watt metal or carbon film	1
100k	¼ watt metal or carbon film	4
330k	¼ watt metal or carbon film	1
1M	¼ watt metal or carbon film	1
1n	Film	1
22n	Film	1
100n	Film	1
1 μ	Electrolytic (35v+)	2

2.2μ	Electrolytic (35v+)	2
10μ	Electrolytic (35v+)	3
100μ	Electrolytic (35v+)	1
1N4007	Rectifier diode	4
1N5817	Schottky rectifier diode	1
LED	3-5mm	1
2N2222A	BJT	4
Footswitch	3PDT	1

DRILL TEMPLTE (1590B)

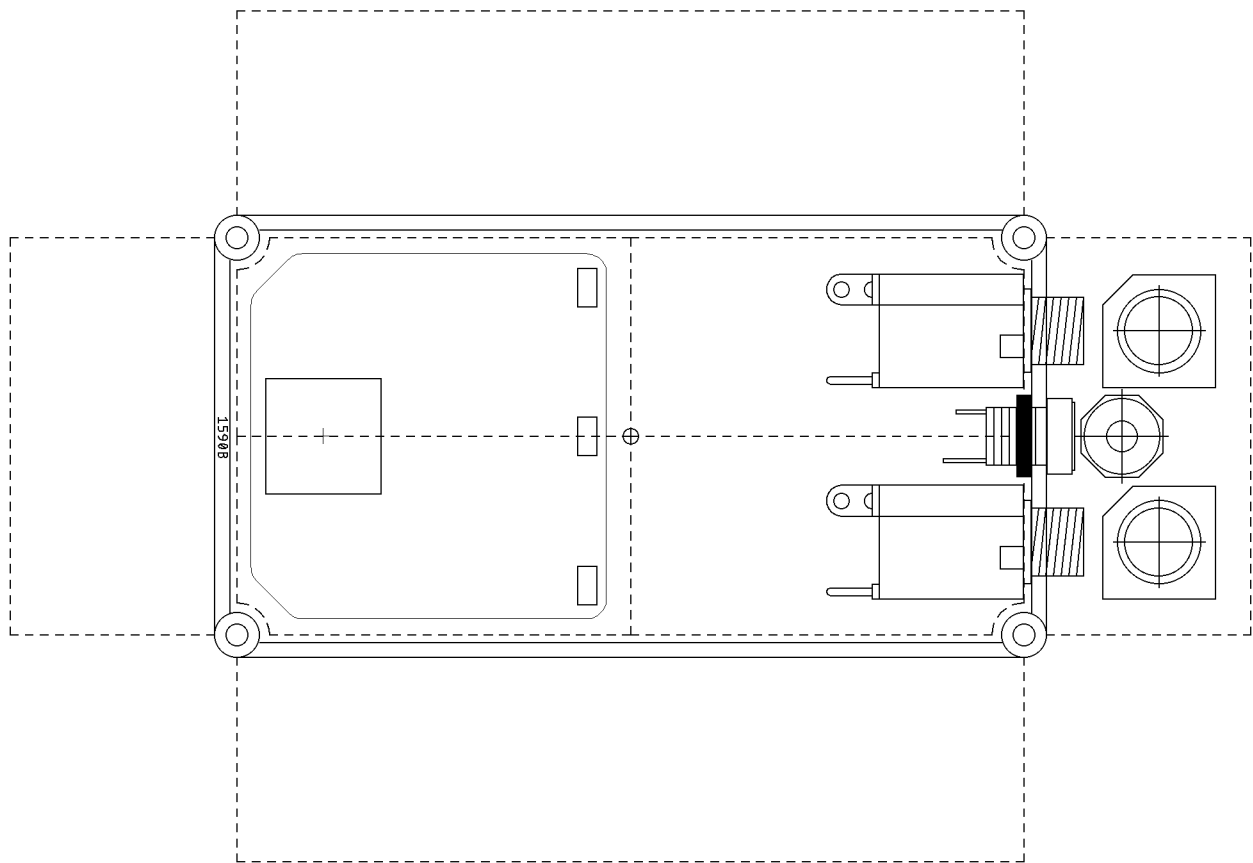

EFFECTS LAYOUTS © 2019
 For DIY and small commercial applications.
 Not for non-peer to peer resale.